

Provided by:
Quik-Brik

NCMA TEK

National Concrete Masonry Association
an information series from the national authority on concrete masonry technology

FLASHING DETAILS FOR CONCRETE MASONRY WALLS

TEK 19-5A

Water Penetration Resistance (2008)

Keywords: cavity filter, cavity walls, construction details, corner flashing, end dams, flashing, moisture, parapet flashing, single wythe walls, splicing flashing, vents, weep holes

INTRODUCTION

At critical locations throughout a building, moisture that manages to penetrate a wall is collected and diverted to the outside by means of flashing. The type of flashing and its installation may vary depending upon exposure conditions, opening types, locations and wall types. This TEK includes typical flashing details that have proven effective over a wide geographical range. The reader is also encouraged to review the companion TEK 19-4A *Flashing Strategies for Concrete Masonry Walls* (ref. 1) which addresses the effect of moisture on masonry, design considerations, flashing materials, construction practices, and maintenance of flashing.

CAVITY WALLS

For cavity walls, as illustrated in Figure 1, the cavity typically ranges from a minimum of 2 in. to a maximum of 4 ½ in. (25 to 114 mm) wide, with a minimum of a 1 in. (25 mm) clear airspace if rigid insulation is placed in the cavity. Cavities wider than 4 ½ in. (114 mm) are permitted only if a detailed analysis is performed on the wall ties per the *International Building Code* and *Building Code Requirements of Masonry Structures* (refs. 2, 3) The 1 in. (25 mm) clear airspace works only if the mason takes precautions to insure that mortar will not bridge the airspace. Such precautions would include beveling the mortar

bed away from the cavity or drawing a piece of wood up the cavity to collect mortar droppings. If precautions are not taken, it is suggested that a wider airspace be utilized, i.e. 1½ to 2 in (38 to 51 mm). Also when using glazed masonry veneer, a 2 in. (51 mm) minimum airspace is recommended with air vents provided at the top and bottom of the wall because of the impermeable nature of the unit. Proprietary insulated drainage boards or mats are available that provide an unobstructed

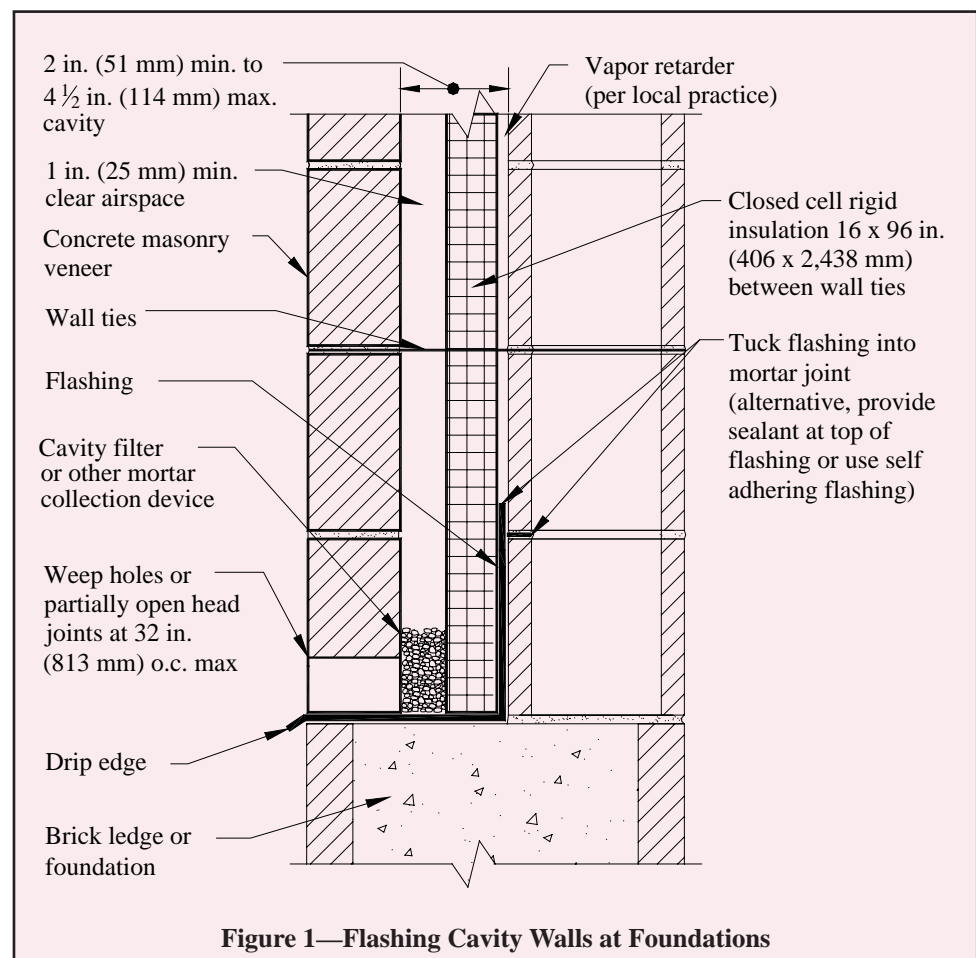

Figure 1—Flashing Cavity Walls at Foundations

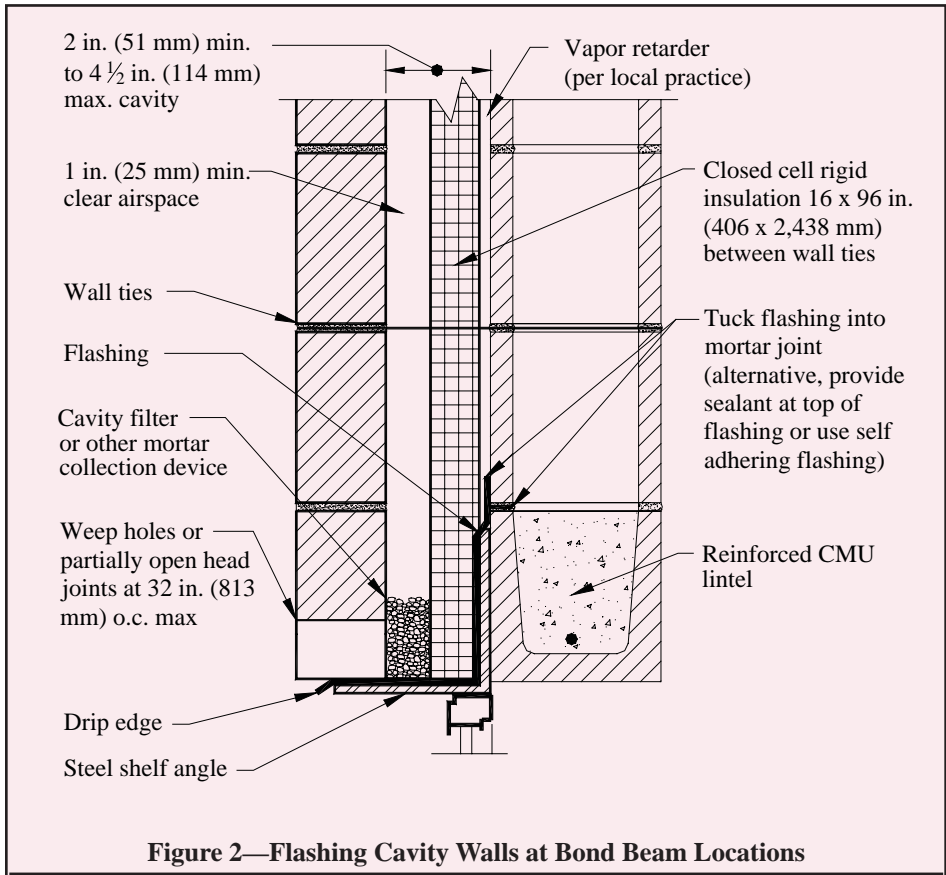

Figure 2—Flashing Cavity Walls at Bond Beam Locations

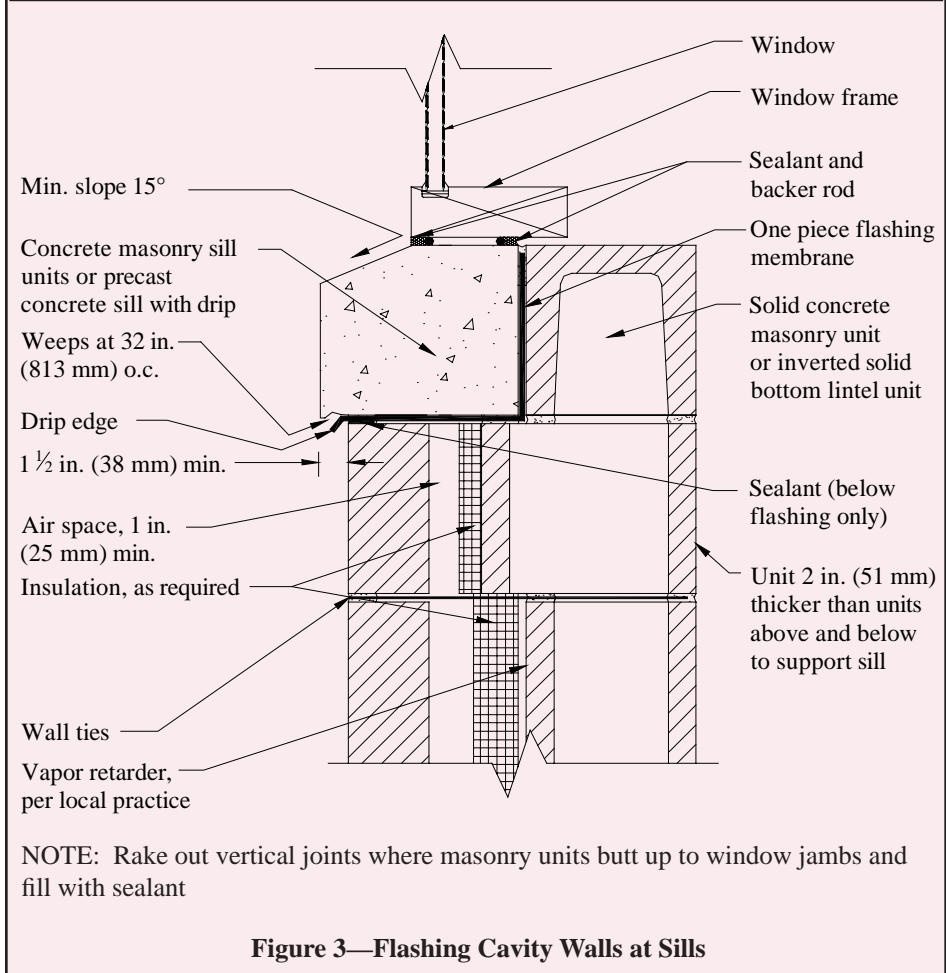

Figure 3—Flashing Cavity Walls at Sills

drainage path that eliminate the need for a clear airspace (ref. 4).

As shown in Figure 1, the flashing in a cavity wall at the intersection of the foundation should be sealed to the exterior faceshell of the backup wythe, project downward to the foundation surface, outward to the exterior face of the wall, and terminate with a sloped drip. Weep holes or open head joints should be located a maximum of 32 in. (813 mm) apart. Flashing at lintels and sills (shown in Figures 2 and 3, respectively) is very similar. Although not shown, vents can be installed in the vertical head joints at the top of masonry walls to provide natural convective air flow within the cavity to facilitate drying. Prefabricated flashing boots available for both single and multiwythe walls are shown in Figure 7.

SINGLE WYTHE WALLS

Flashings in single wythe walls, like cavity walls should be positioned to direct water to the exterior. This is normally accomplished using two narrower units to make up the thickness of the wall and placing flashing between them as shown in Figures 4 and 8. Care should be exercised to insure that surfaces supporting the flashing are flat or are sloping to the exterior. This can be accomplished by using solid units, lintel or closed bottom bond beam units turned upside down similar to Figure 3, or by filling cells of hollow units with mortar or grout.

Flashing of single wythe walls at lintels, foundations, and bond beams is accomplished in the same manner as shown in Figure 4 while sills are shown in Figure 6. Through-wall flashing is used in many areas of the country as shown in Figure 9. However, the bond-breaking effects of this type of detail need to be evaluated in regard to the structural performance of the wall. Additional information for flashing single-wythe walls, particularly architectural concrete masonry walls, and means for providing a higher level of structural continuity at flashings is contained in TEK 19-2A (ref. 5).

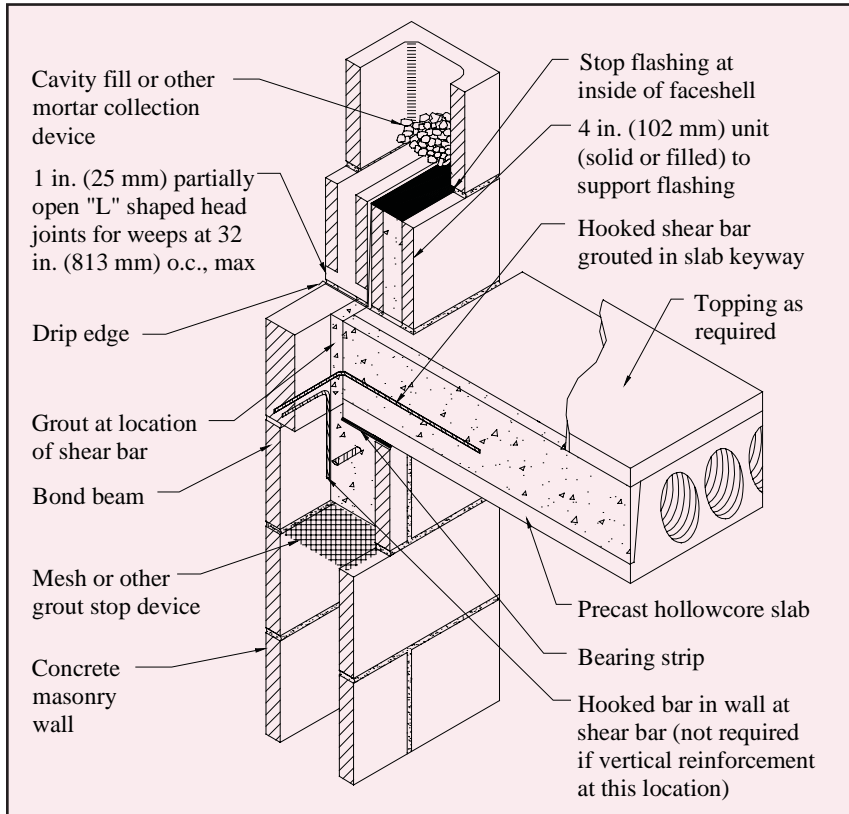

Figure 4—Flashing Single Wythe Walls

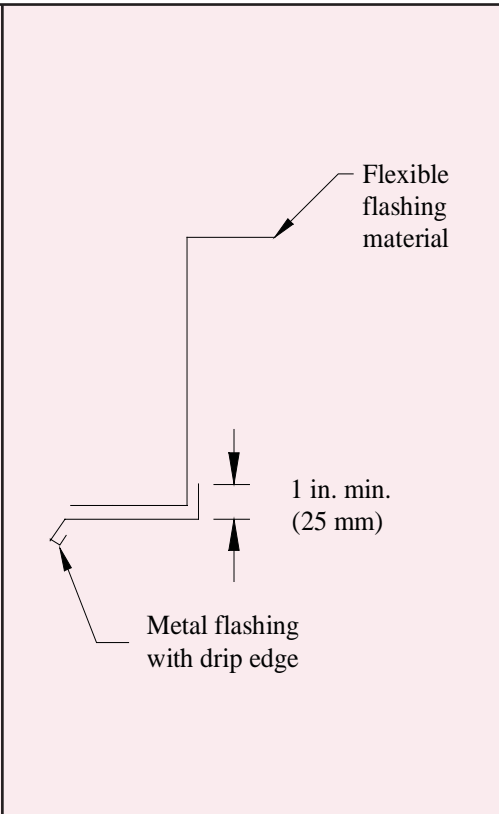

Figure 5—Two-Piece Flashing Detail

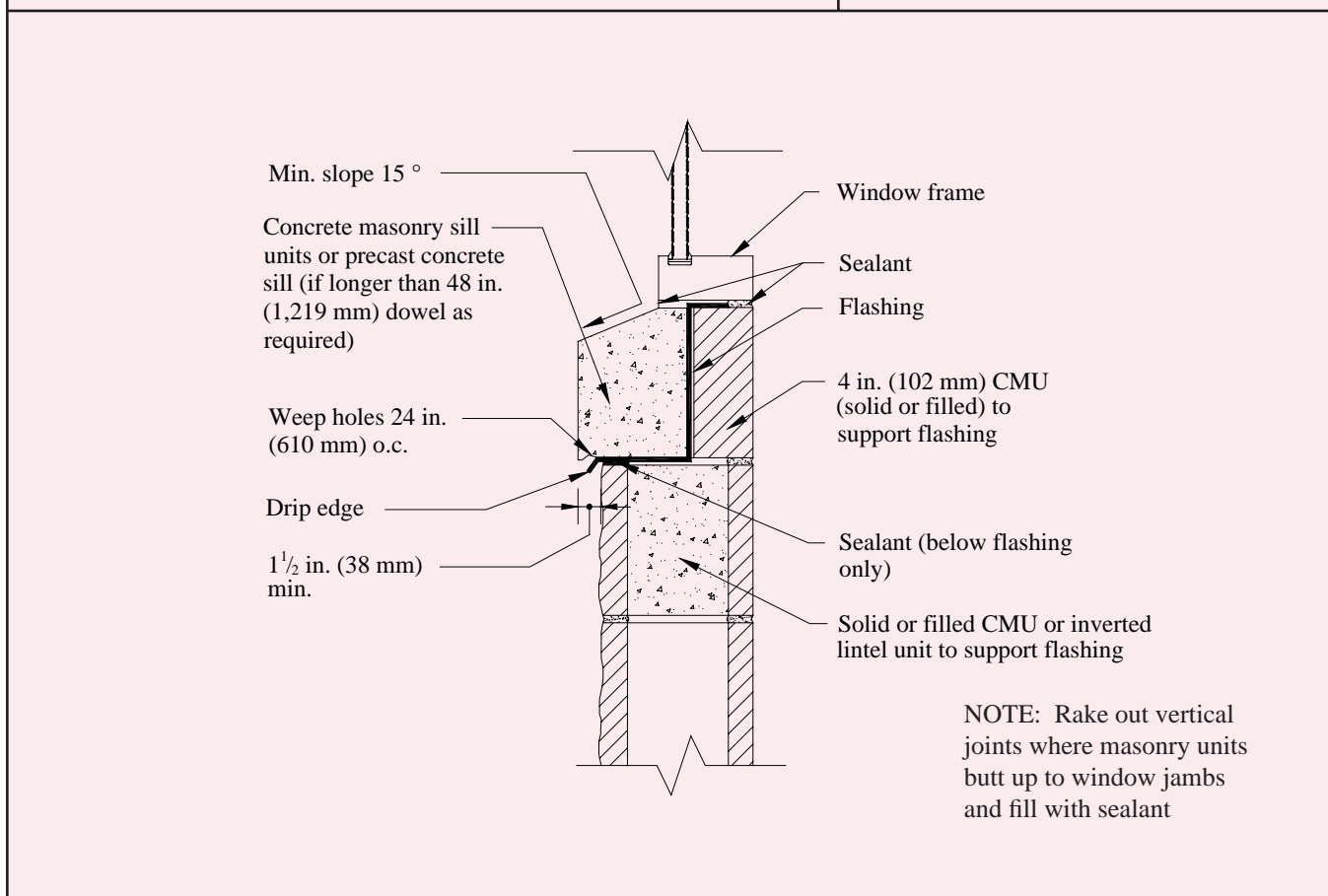

Figure 6—Flashing Single Wythe Walls at Sills

NOTE: Rake out vertical joints where masonry units butt up to window jambs and fill with sealant

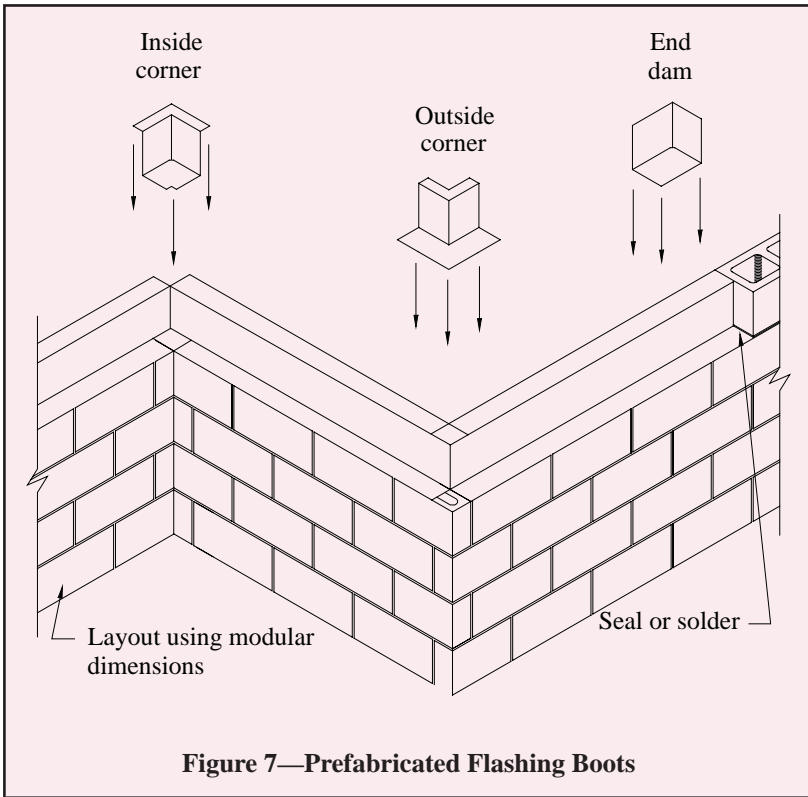

Figure 7—Prefabricated Flashing Boots

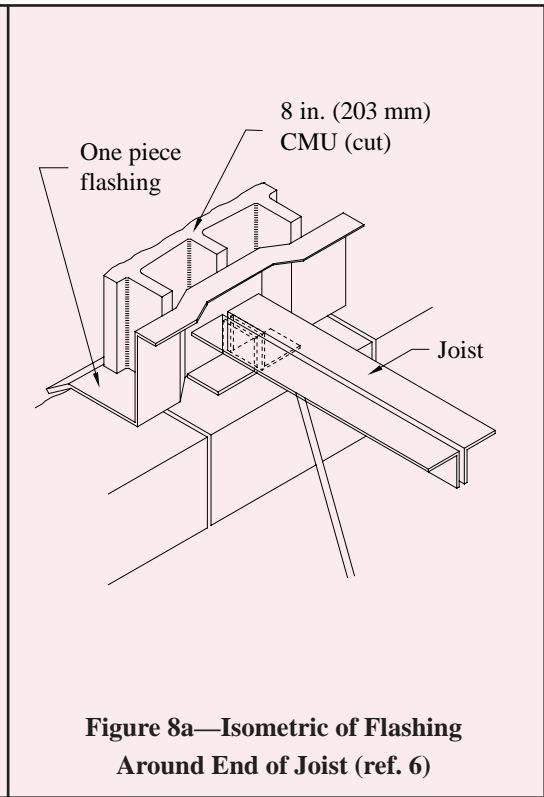

Figure 8a—Isometric of Flashing Around End of Joist (ref. 6)

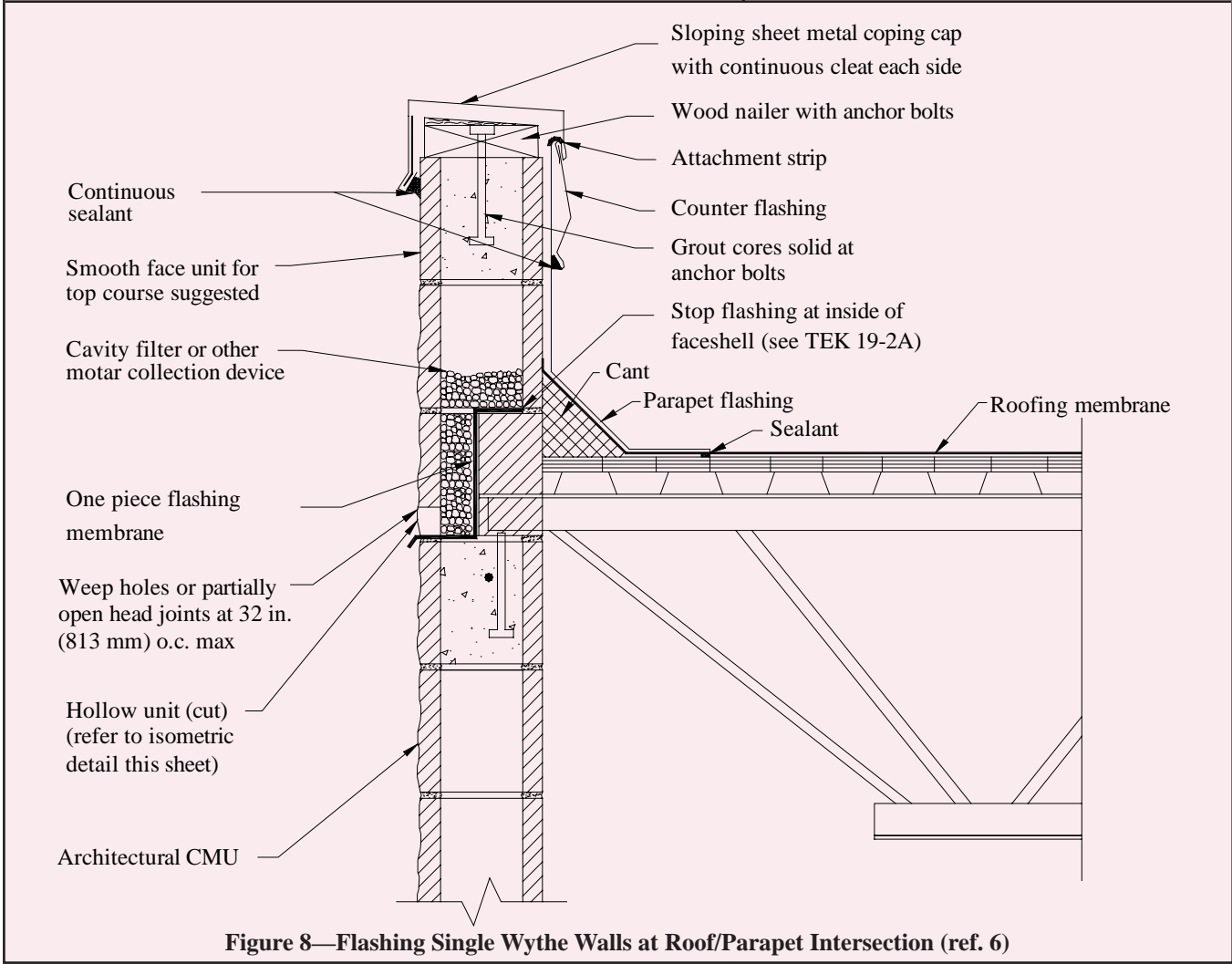

Figure 8—Flashing Single Wythe Walls at Roof/Parapet Intersection (ref. 6)

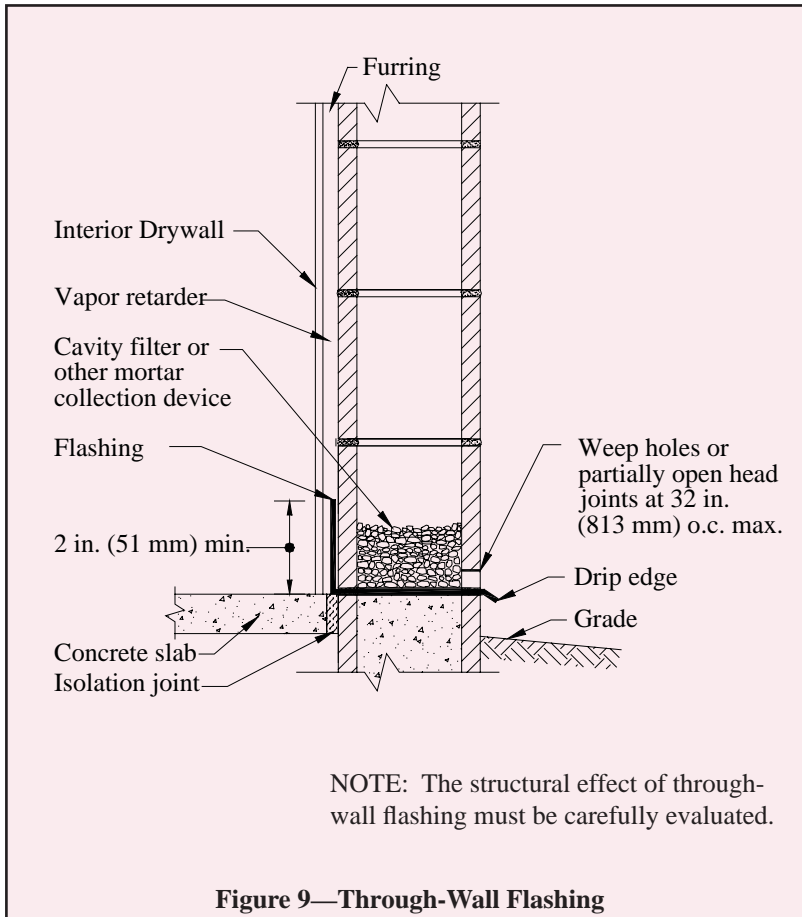
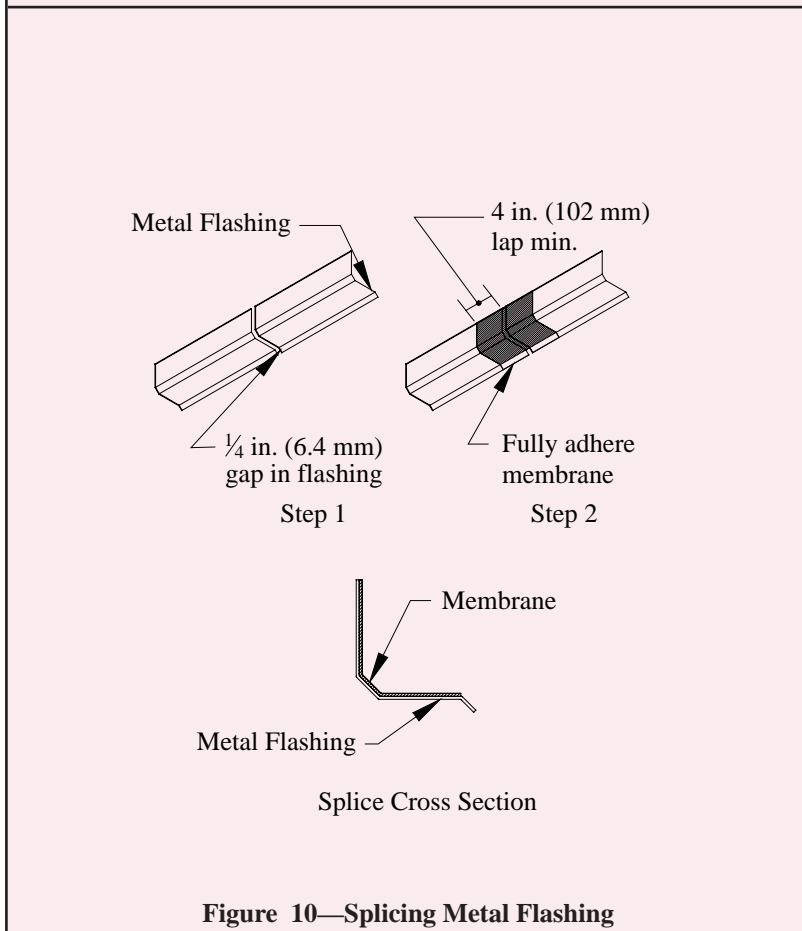

Figure 9—Through-Wall Flashing



Flashing single wythe walls at the ends of bar joists which utilize wall pockets for bearing is shown in Figures 8 and 8a.

FLASHINGS AT COPINGS AND CAPS

The type of flashing detail to use on low-sloped roofs will in part depend on the type of roofing membrane being used. As with any flashing detail, the materials used should result in a uniform and compatible design. For example, joining two materials with significantly different coefficients of thermal expansion (such as metal flashing and bitumen roofing membrane) can cause tearing and failure of the joint. Many roofing membranes also shrink as they age. As a result, roofing membranes extending over the top of a parapet may pull the parapet off the wall as the roofing membrane shrinks. Counter flashing provides a solution to these problems as shown in Figure 8. Counter flashing also facilitates the reroofing process by allowing easy removal and access to the flashing membrane fasteners.

During placement of the final courses of masonry in parapets, and commencing with the second course below the coping/cap location, a grout stop should be placed over cores so that grout can be placed for the positioning of anchor bolts (Figure 8).

In coping installations it is imperative that penetrations of through-wall flashing be tightly sealed to prevent water infiltration. A full mortar bed is required to be placed on the through-wall flashing to allow proper positioning of coping units. Full head joints are placed between the coping units as well as properly spaced control joints. The joints between the coping units should then be raked and a joint sealant applied.

Coping units should be sized such that overhangs and a drip reveal are provided on both sides of the wall. Metal caps require wood plates for anchorage, which in turn are usually attached to the wall with anchor bolts. The cap should be sloped to prevent water from draining onto the exposed surface of the masonry and should extend at least 4 in. (102 mm) over the face of the masonry and sealed on both sides. Smooth face or uniform split face CMU should be considered for use under the cap to ensure a relatively tight fit between the masonry and cap that might be hindered by uneven concrete masonry units such as split-face or fluted units.

INTERIOR WALL TREATMENTS

Concrete masonry walls with an interior treatment may also utilize a through-wall flashing installation of flashings as shown in Figure

9. However, as noted in the figure, through-wall flashings generally create a bond-breaker, which reduces the structural capacity of a masonry wall. This effect should be carefully evaluated before implementing this type of detail particularly in high-wind and seismic areas.

As shown in Figure 9, the flashing should project through the wall and be carried up on the interior concrete masonry surface. Furring strips installed to receive the plastic vapor retarder and the interior gypsum board will hold the flashing in position. This procedure permits any water that may penetrate to the interior surface of the concrete masonry wall to drain out at the base of the wall. Weep holes should project completely through the wall thickness. Vents, if used, should project into the core areas only.

SPLICING FLASHING

When it is necessary to splice the flashing, extra precautions are required to ensure that these discreet locations do

not become sources of water penetration. Flashing should be longitudinally continuous or terminated with an end dam as shown in Figure 7. The splicing of flashing materials consisting of plastic and rubber compounds is achieved by overlapping the joint a minimum distance of 4 in. (102 mm). The lapped area is then bonded together with adhesive if the flashing material is not self-adhering.

Lap splicing of metal flashing is not recommended as it has a different coefficient of thermal expansion than that of concrete masonry. As the temperature fluctuates, the flashing material will expand and contract differently than the masonry material, which can result in sealant failure and a potential point of entry for moisture. A typical flashing splice is detailed in Figure 10. Here, two sections of sheet metal type flashing that are to be spliced are first installed with a ¼-in. (6.4 mm) gap between them to allow for expansion of the flashing. Next, a section of pliable self-adhering membrane (such as rubberized-asphalt) or other pliable membrane set in mastic is fully bonded to the flashing at the location of the gap.

REFERENCES

1. *Flashing Strategies for Concrete Masonry Walls*, TEK 19-4A, National Concrete Masonry Association, 2008.
2. *International Building Code*. International Code Council, 2003 and 2006.
3. *Building Code Requirements for Masonry Structures*, ACI 530/ASCE 5/TMS 402, reported by the Masonry Standards Joint Committee, 2002 and 2005.
4. *Flashing...Tying the Loose Ends*, Masonry Advisory Council, Chicago, IL, 1998.
5. *Design for Dry Single-Wythe Concrete Masonry Walls*, TEK 19-2A, National Concrete Masonry Association, 2008.
6. *Generic Wall Design*, Masonry Institute of Michigan, 1998.

Provided by:
Quik-Brik

Disclaimer: Although care has been taken to ensure the enclosed information is as accurate and complete as possible, NCMA does not assume responsibility for errors or omissions resulting from the use of this TEK.